

I N S T I T U T D ' A E R O N O M I E S P A T I A L E D E B E L G I Q U E

3 - Avenue Circulaire

B - 1180 BRUXELLES

# AERONOMICA ACTA

A - N° 252 - 1982

Controlling the 1ES013 spectrometer for Spacelab  
and its data retrieval

by

C. LIPPENS

B E L G I S C H I N S T I T U U T V O O R R U I M T E - A E R O N O M I E

3 - Ringlaan

B - 1180 BRUSSEL

## FOREWORD

The paper entitled "Controlling the 1ES013 spectrometer for Spacelab and its data retrieval" will be published in the "Bulletin de la Classe des Sciences de l'Académie Royale de Belgique".

## AVANT-PROPOS

L'article intitulé "Controlling the 1ES013 spectrometer for Spacelab and its data retrieval" sera publié dans "Bulletin de la Classe des Sciences de l'Académie Royale de Belgique".

## VOORWOORD

De tekst "Controlling the 1ES013 spectrometer for Spacelab and its data retrieval" will be published in the "Bulletin de la Classe des Sciences de l'Académie Royale de Belgique".

## VORWORT

Der text "Controlling the 1ES013 spectrometer for Spacelab and its data retrieval" wird in "Bulletin de la Classe des Sciences de l'Académie Royale de Belgique" herausgegeben werden.

CONTROLLING THE 1ES013 SPECTROMETER FOR SPACELAB  

---

AND ITS DATA RETRIEVAL  

---

by

C. LIPPENS

Abstract

The Command and Data Management System for Spacelab is described and how it is used to control the Grille Spectrometer, how the experiment data is handled until it finally reaches the Ground Support Equipment in the Payload Operations Control Center for display and storage.

Résumé

Le "Command and Data Management System" pour Spacelab est décrit, comment il est utilisé pour contrôler le Spectromètre à Grille et comment les données expérimentales sont traitées jusqu'au moment qu'elles atteignent l'équipement de support au sol pour affichage et archivage dans le "Payload Operations Control Center".

## Samenvatting

Het "Command and Data Management System" voor Spacelab wordt beschreven, hoe het gebruikt wordt voor de besturing van de Grille Spectrometer en hoe de gegevens van het experiment behandeld worden tot ze uiteindelijk de grondapparatuur in het "Payload Operations Control Center" bereiken waar ze opgeslagen en afgebeeld worden.

## Zusammenfassung

Das "Command and Data Management System" für Spacelab wird vorgestellt. Die Handlung der Kontrol des Grille Spektrometer und der experimentellen Daten bis sie des "Payload Operation Control Center" für Abbildung und Aufspeichern erreichen, ist beschrieben.

## 1. INTRODUCTION What is Spacelab ?

Spacelab is a scientific laboratory, designed and build by ESA in Europe, which will be carried to and from an earth orbit by the American Space Shuttle. It remains attached in the Orbiter cargo bay throughout the flight. Spacelab has a modular design : it consists of two basic elements : - a pressurized module (one or two segments); and - an unpressurized pallet (up to five segments) this allows for a large variety of flight configurations (module only, module and pallet or pallet only). The launch date of the first Spacelab flight is scheduled now for September 30, 1983. The configuration will be a two segment module and a single segment pallet.

The pressurized module consists of a cylinder 5,4 m long and 4 m in diameter closed with two cone-shaped end closures. A pallet segment is U shaped, 4 m wide and 3 m long. The module is connected to the orbiter EVA airlock (EVA = extra vehicular activity) by a tunnel almost 6 m long. The module is equipped with a fixed control center rack, a work bench rack and twelve removable experiment racks. All the experiments will be integrated into the experiment racks before they are slid in the module together with the floor assembly (experiment train). The total weight is 14.515 kg for a total experiment weight of 2.744 kg. Spacelab provides an Environment Control Subsystem, an Electrical Power Distribution Subsystem (the basic electrical power is derived from the orbiter fuel cells), a Command and Data Management Subsystem and Common Payload Support Equipment.

In the next sections we will describe briefly the Command and Data Management Subsystem and how the grille spectrometer interfaces to it.

It will be placed for a nine day mission in a circular orbit : 250 km high with an inclination of 57 degrees.

## 2. THE COMMAND AND DATA MANAGEMENT SUBSYSTEM (CDMS)

### 2.1. Low rate data acquisition and control

Fig. 1 gives a simplified overall block diagram of those CDMS parts which are of direct interest to our experiment. In the module the electrical power is distributed from two EPDB's (Experiment Power Distribution Box) to Experiment Power Switching Panels (EPSP) in each rack. Module experiments derive their power from those EPSP's. Pallet instruments derive their electrical power directly from pallet EPDB's. Experiments receive commands from and send data to CDMS via Remote Acquisition Units (RAU's).

Each RAU has 4 serial Pulse Code Modulated (PCM) command channels  
4 serial PCM data channels  
4 User Time Clock channels (UTC)  
64 discrete on/off command channels  
128 flexible inputs.

Flexible inputs have differential inputs and can be used for discrete inputs : for example : one status bit per input line. Flexible inputs can also be used for analog signals which are then digitized to eight bits in the RAU.

The User Time Clock channels distribute a 1024 kHz clock and an update pulse group (every 250 msec) derived from the orbiter master time unit and therefore synchronized with GMT (Greenwich Mean Time). Serial PCM command and data messages are restricted to a maximum length of 32 16-bit words per message. Up to 21 RAU's are linked by Interconnecting Stations (I/S) on the Experiment Data Bus which connects to the Experiment Input Output Unit. This I/O unit controls the transfer of external data into the computer memory and the transfer of data from computer memory to all peripherals.

Two Input/Output Units and three identical computers are installed in the bottom of the workbench rack : the experiment computer, the subsystem computer and a back-up computer which can take over either the experiment or the subsystem computer. The experiment I/O unit has thus two Direct Memory Access couplers, one to the experiment computer, the other to the back-up computer. The I/O unit has the following interfaces to the rest of the CDMS and the Orbiter.

- RAU and HRM coupler (HRM = high rate multiplexer)
- Data Display Stations (DDS) = Keyboard + Data Display Unit (DDU)
- Mass Memory Unit (MMU)
- Time coupler (output only) 1024 KHz composite clock to RAU's
- Orbiter Multiplexer - Demultiplexer (MDM)
- Orbiter PCM Master Unit (PCMMU)
- Orbiter Time Unit (input only) via Remote Amplifier and Advisory Box (RAAB)

The experiment I/O unit also has monitor outputs to a subsystem RAU. Once initialized, an input-output operation can proceed in parallel with the Central Processor Unit (CPU) use of the memory. I/O has priority however. The subsystem I/O unit connects the subsystem and back-up computer to the subsystem data bus on which simplified RAU's without PCM and UTC capabilities are connected. The orbiter PCMMU is a first downlink possibility, used only for Spacelab housekeeping data, low rate scientific data at 64 kb/s (kilobits per second), two 32 kb/s voice channels, and 64 kb/s orbiter telemetry data . This forms a 192 kb/s data stream which is controlled by the network signal processor and transmitted to the ground via either STDN (Spaceflight Tracking and Data Network) S-band antenna, or the TDRSS (Tracking Data and Relay Satellite System) Ku-band antenna to the TDRSS ground station in White Sands, New Mexico. To bridge non-TDRSS coverage, the 192 kb/s telemetry data are buffered on the Maintenance/Loop Recorder in the Orbiter.

The uplink has a capacity of 216 kb/s via TDRSS Ku-band; via the STDN S-band only 40 kb/s are possible (32 kb/s voice link + 8kb/s command link). Due to sync overhead and coding information the command rate is only 2 kb/s. These 2 kb/s are routed through the Network Signal Processor and the Multiplexer-Demultiplexer into the Orbiter General Purpose Computer (GPC). From there they are sent through the Multiplexer-Demultiplexer (MDM) to the Experiment Input/Output Unit and finally to the experiment computer.

This uplink will be used to alter experiment data sets on the MMU and to modify Timelines. It can even be used to command experiments from the ground, although this will not be very practical since uplink commands have to be prepared, formatted and scheduled in advance.

The MMU installed in the Control Center Rack is a magnetic tape unit with 8 data tracks and one prerecorded control and address track. Each track is divided into 8 files, each of which has 64 subfiles. Each subfile has 32 blocks of 512 words. Tracks are read/written in alternate directions. The MMU is used for storage of all basic and application software, the data display skeleton formats and data for experiments.

One Data Display Station is installed in the Control Center Rack, another in the orbiter aft flight deck. They form the most important interface between the crew and the system. The 12 inch diagonal screen can display three colors : green, yellow and red. It can display a total number of 999 symbols - 22 lines of 47 symbols from a 128 symbol set. It has a vector display capability. The keyboard covers the full ASCII set and has an extra 25 function keys.

The Orbiter Master Time Unit (MTU) generates a modified IRIG-B time code with a resolution of 10 ms and a 1024 KHz clock signal (1  $\mu$ s resolution). These signals are connected via the RAAB in the module



to both Input/Output units and the High Rate Multiplexer (HRM), where GMT information is inserted in the PCM format. In the I/O unit time coupler a 1024 KHz composite User Clock Signal (UCS) is formed and distributed to the experiment RAU's together with a UCS update signal every 250 msec. The time coupler can be programmed to provide real time interrupts to the experiment computer for a period in multiples of 10 milliseconds.

## 2.2. High rate data acquisition

The high rate data acquisition system is shown in the upper part of Fig. 1. The HRM (High Rate Multiplexer) is the core of the system. It has the following inputs :

- 16 experiment input channels with data rates up to 16 Mb/s
- 1 DACH's (Direct Access Channel) with a maximum bit rate of 50 Mb/s
- 2 computer input channels (S/S and exp.) maximum bit rate 25.6 kb/s
- 1 GMT time channel resolution 10 msec
- 3 voice channels, total bit rate 125 kb/s
- 1 input from the HDRR (High Data Rate Recorder), bit rates :  
32-24-16-  
12-8-4-2 Mb/s
- 1 input from the orbiter Payload Recorder at a fixed 1 Mb/s.

It has three output channels :

- 1 to the HDRR at bit rates 32-16-8-4-2-1 Mb/sec
- 1 to the Payload Recorder bit rates 1000-500-250-125 kb/s
- 1 to the Ku-band Signal Processor (KUSP), bit rates 48 Mb/s, 32 Mb/s to 125 kb/s in binary steps.

The KUSP has three inputs (5 Mb/s, 4 Mb/s, 2 Mb/s). Many configurations are possible. They are controlled by the subsystem

computer dependent on downlink availability, Ku-band Signal Processor operation mode and multiplexed data rate.

The inputs are completely asynchronous with the HRM internal clock. Each input has a 16 bit shift register in which user serial data is clocked in at the user clock. Then, after 16 bits, the contents are loaded into a 4 x 16 bit buffer. In a sequence determined by the format loaded, the format controller fetches one 16 bit word out of the input buffer and transfers it to the output register where it will be serialized.

In case of an empty input buffer a fill word is introduced, which can be identified as such by means of the fill identification part of the frame overhead. During demultiplexing on the ground, fill words are automatically suppressed.

The output format has a length of 8 frames. Each frame contains 96 16-bit words organized in 6 lines of 16 columns for all output bit rates except the 48 Mb/s rate where they are organized in 8 lines of 12 columns. Even frames start with a sync pattern, odd frames with a status pattern. The fill information is in the last column of each frame. The sync pattern has a 28 bit sync and a 4 bit frame counter. The status pattern has configuration information and a 8 bit GMT channel subcommutated over 32 frames.

The HDRR is used to record HRM output during periods of non-TDRSS coverage. Later, when the downlink is reestablished, those tapes are played back in reverse direction. This can be done at a different speed than the record speed. The data is then interleaved with real time experiment data. When not needed for recording HRM output, the HDRR can be used for recording DACH or experiment channels. The orbiter Payload Recorder is used in the same way as a lower rate back up, or when tapes have to be changed on the HDRR.

The Ku-band signal processor feeds the Ku-band transmitter. The signal is transmitted to one of the 2 geostationary TDRSS satellites which relays the signal to the White Sands, New Mexico ground Station.

Due to the low orbit and beam blocking by the orbiter itself direct links are only possible about 70% of the time. The STDN S-band system used for housekeeping and low rate scientific data is even worse. Using all existing STDN ground stations, the coverage is less than 30%. Once TDRSS is operational, the number of STDN ground stations will be reduced. Then only 5% coverage will be possible.

The signals received at the ground stations are recorded on magnetic tape for post-mission data handling. They are routed over ground links to Mission Control Center (MCC) and POCC (Payload Operations Control Center) in Houston.

After signal conditioning, the bit synchroniser delivers either the Direct Access Channel or the PCM time multiplex. A High Rate Demultiplexer (HRDM) will reconstitute the 16 experiment channels, the two CDMS computer channels, the HDRR channel, the Payload Recorder channel and the GMT. The experiment channels are distributed to the POCC user rooms where they are fed into the Experimenters' Ground Support Equipment (EGSE). The GMT is stripped out of the status pattern in the PCM overhead and available to users as a GMT burst time or, after transformation and modulation of a 10 KHz carrier, as an IRIG A time code. The experiment and subsystem computer channels are fed into the POCC computer real time and near real time data base. Intelligent terminals in the POCC user rooms are connected to this computer. The user can program these terminals to display those near real time data base parameters of interest to him. The POCC computer also has four serial synchronous output channels which can be connected to EGSE in the user rooms. They can be programmed to output the Experiment Computer Output Channel data from a single experiment.

Reverse play-back data from the HRRR or Payload Recorder on board are again tape recorded as they come out of the HRDM.

Upon demand these tapes are played back again in reverse with the correct speed through a second stage HRDM to reproduce experiment data taken during non-coverage periods at the bit rate they were entered into the HRM.

### 3. THE GRILLE SPECTROMETER CONTROL AND DATA COLLECTION

#### 3.1. Description

Experiment 1ES013 for Spacelab 1 is a grille spectrometer taking medium resolution ( $0.1 \text{ cm}^{-1}$ ) spectra in the near infrared (2.5-13  $\mu\text{m}$ ). It has two detectors cooled by a Joule Thomson to  $-200^\circ\text{C}$ . A set of 8 selectable filters in front of each detector isolates the diffraction order of a scanning grating.

Spectra will be taken in small wavelength intervals to determine minor constituent concentrations in the upper atmosphere. Two modes of operation will be used : absorption mode, using the setting or rising sun as a source and emission mode, looking at a constant limb altitude. Therefore a gimballed heliostat mirror which is in front of a 6 m focal length telescope with a 30 cm diameter primary mirror, collects the light and concentrates it on the grille, working in transmission.

The grille is a plate with alternating reflecting and transparent zones limited by equilateral hyperbolas. The distance between these hyperbolas defines the resolution independantly of the throughput defined by the total grille area. A vibrating parabolic collimating mirror modulates the light. After diffraction on the grating the light is collected and concentrated on the grille again, which acts in reflection this time. After separation by a beam splitter the light goes through selectable filters and reaches the detectors.

Once the heliostat is positioned within a 10 degrees cone around the sun a sunpointer locks this mirror to the sun and tracks it. In emission mode this mirror has to compensate any attitude changes. For calibration purposes, a calibration mirror can be placed in the optical path so that the instrument looks at an internal light source through a gas filled cell.

After preamplification the detector signals are synchronously demodulated by two reference signals, 90 degrees out of phase at the modulating frequency. They deliver the sine and cosine components of both detector signal intensities. After digitizing each of these four signals to 12 bits they form together with the 18 bit grating encoder value a scientific data point. Two hundred such data points are taken per second. A single data point with a synchronization pattern, an experiment identification pattern and a frame counter form a frame for the experiment's dedicated HRM input channel. The frame counter counts from zero to seventy-nine. At frame count zero the whole frame is replaced by a status frame. At frame count forty, the frame is replaced by a status + GMT frame. A microprocessor controls the operation of the whole spectrometer, which is installed on the pallet.

A second box of electronics (EMOD) is installed in the module. This box controls the pallet instrument and is equipped with two microprocessors. EMOD communicates with EPAL - the pallet electronics - by two dedicated asynchronous PCM lines. Two other lines bring the HRM clock and HRM data to EMOD.

EMOD picks out the status information frame and status + GMT frame (a total of 5 per second) and transmits this information to the experiment computer via the PCM data line. Upon request from the experiment computer during calibration or absorption mode a small 250 data point slice will be taken out of the HRM measurement data stream by EMOD, stored in its internal memory and transmitted to the experi-

ment computer at the General Measurement Loop (GML) rate of 5 messages per second. Each message contains one actual status message and three measurement messages from the EMOD buffer. Graphics application software in the experiment computer will display this spectrum slice on the DDU for crew interaction.

The unmodified HRM comes out of EMOD and is connected to the dedicated HRM experiment input channel. EPAL has direct interfaces to CMDS and the experiment computer via RAU number 20. These are (see Fig. 1) : 9 discrete commands (DC), 16 Analog parameters (AP) and 3 discrete parameters (DP).

The analog parameters are : six temperature measurements, six power supply voltage monitorings, the nitrogen pressure of the cooling system and three error signals of different alignment servo systems.

The discrete commands are used to switch main power, epal, detector cooling and thermal control on and off and the calibration lamp off. The discrete parameters monitor main power, epal and thermal control status.

In the same way EMOD has four discrete commands, four analog parameters and two discrete parameter connections to the RAU number 3. Its most important interfaces are, however, serial PCM command and data lines.

### 3.2. Operation

The scanning of a spectral window is defined by a set of parameters: grating encoder values for begin and end point of the scan, filter wheel positions and gain settings for the two detector channels. Forty different sets of such parameters called "windows", numbered from 24 to 64, are stored in read only memory (ROM) in EMOD. The

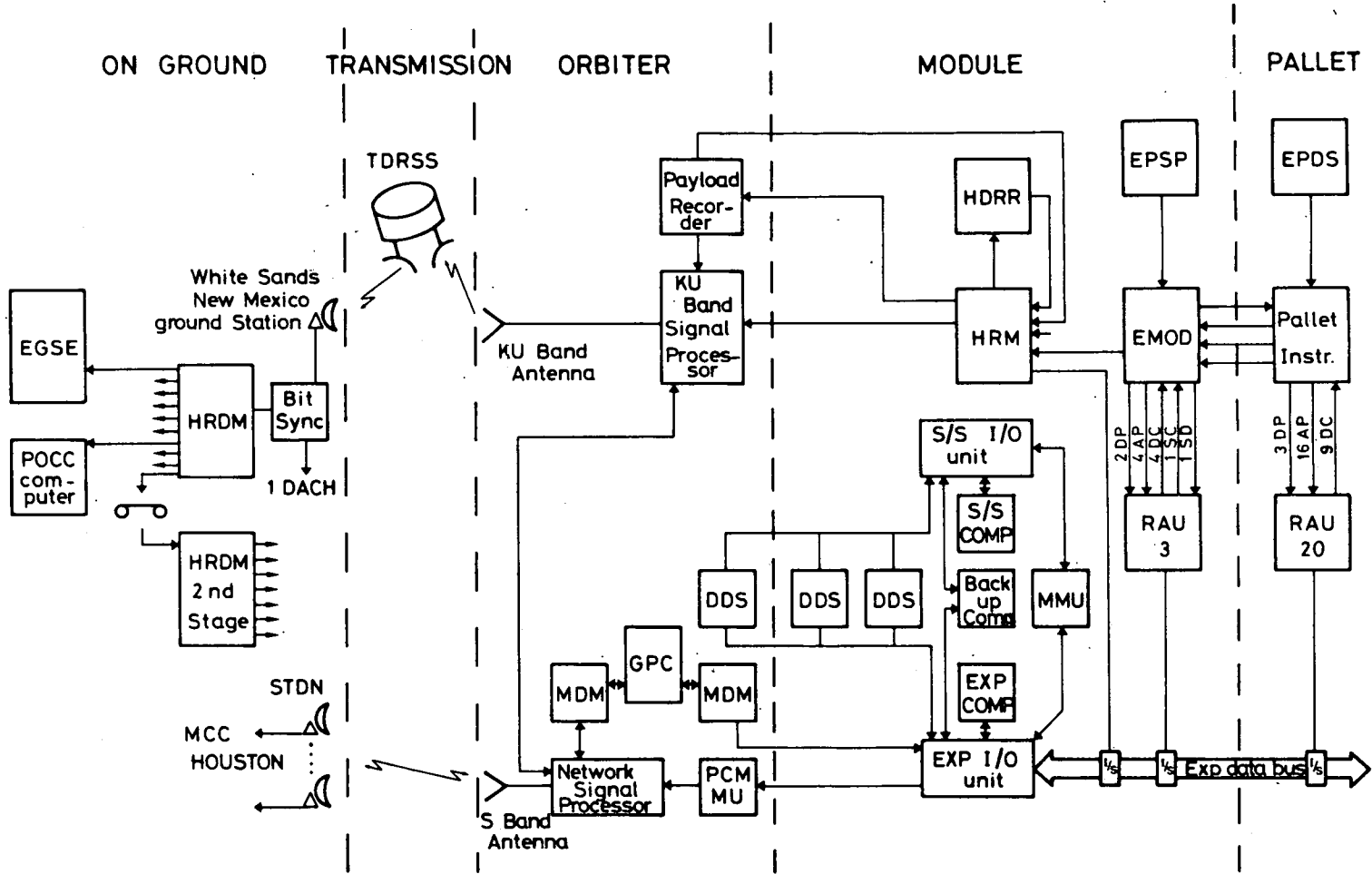

Fig. 1.- Simplified CDMS block diagram.

windows numbered from zero to 23 are stored in random access memory (RAM) and can thus be redefined during the flight by so-called window definition messages sent by the experiment computer via the PCM serial command channel.

A sequence of these "windows" is called a program. For each of the possible modes (absorption sunrise, absorption sunset and emission) 19 predefined programs are stored in ROM and one is programmable and stored in RAM. Program definition messages from CDMS will define these programs, which are numbered 20, 40 and 60.

The emission mode program consists of up to eight phases, each phase being defined by a window number, a number of scans and an altitude code. At the start of a phase the altitude code is sent to the CDMS computer. It will calculate the required azimuth and co-elevation setting needed for the heliostat mirror, taking into account the orbiter attitude and horizon sensor data. These calculations are reexecuted every two seconds and the results are sent to EMOD as a pointing message over the serial PCM command link. Between two phases with different altitude codes EMOD will automatically insert a calibration program.

Calibration is a special mode. A mirror is switched in the optical path to make the instrument look at an internal source through a gas filled cell. The grating scans a large spectral window with a large number of spectral features three times. Upon request, a 250 point slice containing a typical methane doublet is sent to the experiment computer for graphic display. The crew introduces an encoder value offset to compensate the shift if the doublet is not in the middle of the screen. This encoder offset is sent to EMOD which will apply this correction to all the spectral windows. At the end of an operation sequence it will be stored on the MMU for later use.



The absorption programs have twelve phases. Each phase defines two windows which will be scanned alternately. These windows need not be different, however. This time the duration of a phase is not defined by a number of scans but by the time it takes for the sun to cross the altitude zone boundaries of the phase. In fact, the atmosphere has been divided into twelve arbitrary layers. Before the absorption sequence starts, the experiment computer calculates the predicted times at which the sun-orbiter vector will cross these 12 layer boundaries from the orbiter state vector and the ephemeris data. EMOD is informed of these 12 times in a set of PCM time level messages sent to it 30 seconds before the absorption sequence starts. Since EMOD's internal time counter is synchronized with GMT by GMT messages from the experiment computer, it is able to interrupt a scan when the moment has come to switch to the next phase. The PCM status + GMT messages sent back to the experiment computer contain heliostat azimuth and elevation encoder values, the 16 least significant bits of the EMOD GMT counter (10 msec resolution) and a bit indicating sun lock status.

The experiment computer will compare these values with its own predicted sun position and extract the systematic error by applying statistical methods. These systematic errors due to misalignment between the orbiter Inertial Measurement Unit, the Horizon Sensors and the instrument will be stored on the MMU and used as corrections for the next occultation. This can help lock in on the rising sun sooner.

### 3.3. Experiment Computer Application Software (ECAS)

Fifty K words of the experiment computer's 64 K word memory are reserved for the operating system ECOS. The remaining 14K are shared by all experiments which need application software. The operating system executes the timeline commands but can accept commands from the crew keyboard, from POCC via uplink and orbiter MDM and from application software. ECOS governs all input/output by the GML (General Measurement Loop), polling the RAUs for analog and discrete

input once per second and for asynchronous PCM ten times per second through a Configuration Data Table (CDT). Data needing special treatment are transferred to ECAS. Other data can be limit-checked and displayed by ECOS only.

For the first Spacelab flight, so many different experiment inputs/outputs are defined that they do not fit in a single CDT. This implies in-flight CDT reconfiguration, during which nothing else can be done.

Experiment 1ES013 has such an extensive ECAS that it had to be segmented and still requires all of the ECAS allocated memory. The graphics display software even resides in system area memory otherwise used for timeline updating. The software has a common root and six different overlays, three for absorption and three for emission. These three different overlay versions are required to deal with different sources of attitude data (IMU only, 1 horizon sensor head or both horizon sensors heads active - a horizon sensor being inoperational when the sun or moon is in the field of view).

The root contains all interface control routines for communicating with the experiment and with ECOS. In addition it contains support for unattended calibration and for the message reception for the Graphics ECAS. In the worst case, loading an overlay from the MMU can take up to 100 seconds.

For all European ECAS a common structure was used, cutting the software in "phases". The chaining of these phases is automatic or manual. Upon detection of a major problem the cycling software sends an error message to the crew and goes to standby. Manually, any phase can be selected now and executed. Warning messages can be sent without ECAS going to standby. All error messages are overridable to avoid alarms when the status monitor circuitry itself is failing. Table 1 lists the ECAS phases for 1 ES013.

TABLE 1.- ECAS phases

<u>Phase</u>	<u>Description</u>
10	experiment set-up
20	program message reception
30	absorption initialisation
31	DEP initialisation (absorption)
35	absorption mode
40	absorption cycle
50	emission initialisation
51	DEP initialisation (emission)
55	emission cycle
56	elevation calculation
99	shut down

Normally the ECAS is loaded from MMU upon a timeline command. Another command starts the execution of the set-up phase. The following sequence takes place :

Phase 10 :

- switch main 28 V on : the instrument consumes 5 W in this passive state. Only discrete output parameters and one EPAL temperature are valid
- verify the temperature of EPAL to be in safe limits, otherwise an alarm is raised and ECAS goes to standby
- switch on the detector cooling. This command is repeated four times, since there is no status return indicating that the detector is really switched on
- A 90 second delay is built in to allow the detector to cool down. In the mean time ECAS data are read from the MMU
- EPAL and EMOD are switched on. Now all experiment data become valid. The instrument starts sending HRM and PCM. The PCM Data Processing Routine recognises and decommutates status messages and status + GMT messages. All status bits are transmitted to the POCC through the Experiment Computer Output Channel, together with all analog and discrete parameters, ECAS status information, ECAS command history, error message log, horizon sensor data and orbiter position, velocity, attitude and attitude rate data. A subset of the experiment data is displayed on the DDU.
- the heliostat mirror integrity bit is checked and if OK the heliostat is unlocked, otherwise an alarm is raised and ECAS goes to stand-by
- when unlocking is confirmed an initial pointing message is sent to position the heliostat mirror to mid-course.

ECAS is now in phase 20 waiting for a timeline or crew command to start a calibration, emission, absorption or shut down. Shut down and absorption commands have priority. The others are queued.

Two types of calibrations are possible. Unattended calibration (graphics ECAS not loaded): ECAS sends a PCM calibrate command to EMOD which handles the whole procedure automatically. At the end of the calibration the instrument returns to the standby state, ECAS detects this and goes to phase 20, awaiting the next command.

For attended calibration (the graphics ECAS has been loaded by the crew), ECAS sends an Enable Measurements Message to EMOD together with the calibrate command.

The PCM Data Processing Routine will extract the measurement messages as well, and communicate them to the Graphics ECAS, which will calculate the signal amplitude out of its sine and cosine component for display. The crew verifies the methane doublet position and interacts if necessary.

For absorption, the correct overlay has to be loaded. The sun-direction is calculated every five seconds and pointing messages are sent to EMOD. The predicted layer crossing times are communicated to EMOD. If the program number is twenty or forty, window definition messages and program definition messages are sent to EMOD. Finally the sequence selection message starts the selected absorption program. When the graphics ECAS is present, EMOD continuously sends spectrum slices for display. At the end of the absorption program the instrument returns to the standby state. ECAS calculates the azimuth and elevation correction terms.

In emission mode, window and program definition message are sent if necessary. The emission program is started by a sequence selection message and ECAS calculates pointing directions upon reception of the altitude code from EMOD, sending updated pointing messages every two seconds.

The Shut-down phase saves the calculated pointing and grating correction on the MMU and sends a stop command to bring the instrument back to standby mode. Then it switches off the detector cooling, sends a "lock" command to shut and lock the heliostat and waits 65 seconds for the heliostat closure and MMU write to finish. If the detector temperature has not risen by now, an alarm is raised and ECAS goes to standby. Finally, the Shut down phase switches off EPAL, EMOD and the main power.

### 3.4. The Experiment Ground Support Equipment (EGSE)

As described, the instrument was designed to be operated through the Spacelab experiment computer and its RAU's. In order to operate the instrument stand alone for testing purposes and during integration an EGSE was needed which simulated functionally the experiment computer and its RAU's. A Hewlett Packard 2100 computer was selected, operating in RTE II operating system (RTE = real time executive), which is a real time foreground/background multiprogramming environment. The machine is equipped with a 64 k byte memory an HP 7900 cartridge disc mass memory, an HP 7970B 800 bpi magnetic tape unit, an HP2621 system console and an HP 2648 graphics terminal equipped with a Tektronix 4632 video hard copy unit and an HP 2631 A printer. An HP 2323 analog subsystem completes the standard interfaces. A specially built set of interfaces was necessary for HRM, PCM Data, PCM Command and ECOC. Standard interface cards were used for Discrete Input/Outputs, EPAL-EMOD links and IRIG-A GMT.

Several EGSE software packages were prepared. A first set was necessary during the design phase of the spectrometer and interacted with the grating positioning control only. A second set replaces EMOD and part of the CDMS. It was used for troubleshooting and part of the qualification tests. A third software package simulates functionally the complete CDMS and is used to operate the instrument in flight simulation. This is the most complicate software set. And finally we have

the software which will be used in the POCC. It has three interfaces to CDMS :

- HRM input from the HRDM
- IRIG-A GMT as stripped out of the HRM status overhead and converted
- a synchronous serial line from the POCC computer delivering ECOC downlink bursts.

No spectra will be calculated in real time. All data will be recorded on digital magnetic tape. All parameters from the three sources will be displayed in real time and updated every second. This will allow the scientist to monitor the instrument and ECAS operation.

A set of conversational off-line programs reads back the digital tapes and draws quick look graphic spectra displays. They allow averaging of spectra, zooming on spectral features and so on. Other programs list status and command history. A second, almost identical EGSE will be used to do these off-line operations. Only magnetic tapes are transferred between the two systems.

There is no need for real time spectrum display because reaction time is too long mainly due to the uplink bottleneck and the short duration of a sunrise or sunset sequence. Between two absorption sequences there is sufficient time to make spectra displays and, if necessary, to change the selected program number for the next opportunity. Even new programs and windows can be built, uplinked and stored on the MMU. Alternatively, the crew can be asked by voice link to do these modifications. They can use a set of special ECAS to build windows and programs and store them on the MMU. There are eight subfiles which each contain 24 programmable windows and the definition of a program numbered 20, 40 or 60.

#### 4. CONCLUSION

As shown, experiment 1ESO13 extensively uses the potential offered by the CDMS and crew presence, maintaining the possibility of operating the instrument without crew intervention for when they are not available. The control of all parts of the instruments is governed by an hierarchy of Dedicated Experiment Processors (DEPs) which respond very quickly to external events.

The Spacelab experiment computer is used for execution of the timeline, for calculation of the pointing direction and for display of some crucial parameters. If an anomaly arises an alarm is raised. The crew can investigate and respond to it. They can even point the instrument to the sun "manually" via their keyboard in case of an ECAS failure. Their principal task is to verify the wavelength calibration and find the corrections if necessary. The loop closed by the scientist in the POCC user room is the slowest one and will only be used for re-planning several hours in advance.

#### 5. ACKNOWLEDGEMENT

We want to thank prof. M. Nicolet, who started our interest in infrared spectrometry, the engineers and technicians of ETCA, Charleroi, who built the hard- and software and were able to respond to design changes during the project made necessary by specification changes. It should be remembered that the Orbiter, Spacelab and experiments were all developed in parallel. Our special thanks go in this respect to Mr. Henrard and his group who designed the electronics hardware, to Mr. Damoiseau who wrote the EPAL software, to Mr. Collard for the EMOD software and to Mr. Hennecar who wrote the EGSE software. We also thank Mr. Frimout in his role of experiment coordinator and everybody at SPICE in Cologne for their help. Last but not least we want to thank the ESOC group in Darmstadt who did a



marvelous job in writing the ECAS, and especially Mr. John Dodsworth,  
Mr. Fraiture , Nigel Head and Peter Dubock.

## REFERENCES

Spacelab Accomodation Handbook, (ESA-NASA).

Instrument Interface Agreement (SPICE-ESA, FSLP-IS-003, issue 3, April 1981).

Spectromètre pour la première mission Spacelab par Jean Besson, André Girard, Marcel Ackerman et Dirk Frimout, La Recherche Aérospatiale n° 1978-6, p. 343-453.

Scientific programs for the Spacelab ESO13 Grille Spectrometer, C. Muller and J. Laurent, Bull. Cl. Sci. Acad. Roy. Belg., submitted (1982).